

GENERAL NOTES

1. ALL AXLES AND SHAFTS ARE CHROME PLATED.
2. ALL ROLLERS AND PIVOT POINTS ARE EQUIPPED WITH TEFLON SELF-LUBRICATING BEARINGS.
3. 3" VERTICAL AND 4" HORIZONTAL TOE CLEARANCE SIDES.
4. ADVANCE LIFTS, INC. TO SUPPLY:
 - (1) PREWIRED 18' LG. POWER CORD (FROM LIFT BASE TO PLUG).
 - (1) UP/DOWN PUSHBUTTON PENDANT TYPE NEMA 1, 3, 3R, 4, 4X.
5. FINISH: BLUE PAINT.
6. TYPICAL ELECTRICAL DIAGRAM FOR THIS UNIT: E22-1320.
TYPICAL HYDRAULIC DIAGRAM FOR THIS UNIT: H13-256.

SPECIFICATIONS:

CAPACITY : 10,000 LBS MAX. LIFTING CAPACITY
8,000 LBS MAX. AXLE CAPACITY ENDS

PLATFORM : 72" X 120" SAFETY TREAD DECK
REMOVABLE GUARDRAILS - STEEL
18" X 60" STEEL HINGED BRIDGE WITH CHAIN
42" X 54" CHOCK RAMP- STEEL
63" BETWEEN CYLINDER UPRIGHTS
SAFETY CHAINS

SPEED : 11 FPM

TRAVEL : 54" (FROM A 6" LOWERED HEIGHT)

LOWERED HEIGHT : 6"

POWER UNIT : 7.5 HP MOTOR, 230V 60Hz 3PH
SELF CONTAINED AND PRE-WIRED

CONTROLS : UP/DOWN PUSHBUTTON PENDANT
TYPE NEMA 1, 3, 3R, 4, 4X

IN NEMA 12 ENCLOSURE : MAGNETIC STARTER, W/ OVERLOAD
230V TO 24 V CONTROL TRANSFORMER.

VOLTAGE: 230V / 3PH
ADVANCE TO SUPPLY NEMA L15-30P PLUG
CUSTOMER TO SUPPLY: NEMA L15-30R RECEPTACLE

APPROXIMATE SHIPPING WEIGHT: 5,045 LBS.

ALL DIMENSIONS ARE GIVEN IN INCHES UNLESS OTHERWISE NOTED.

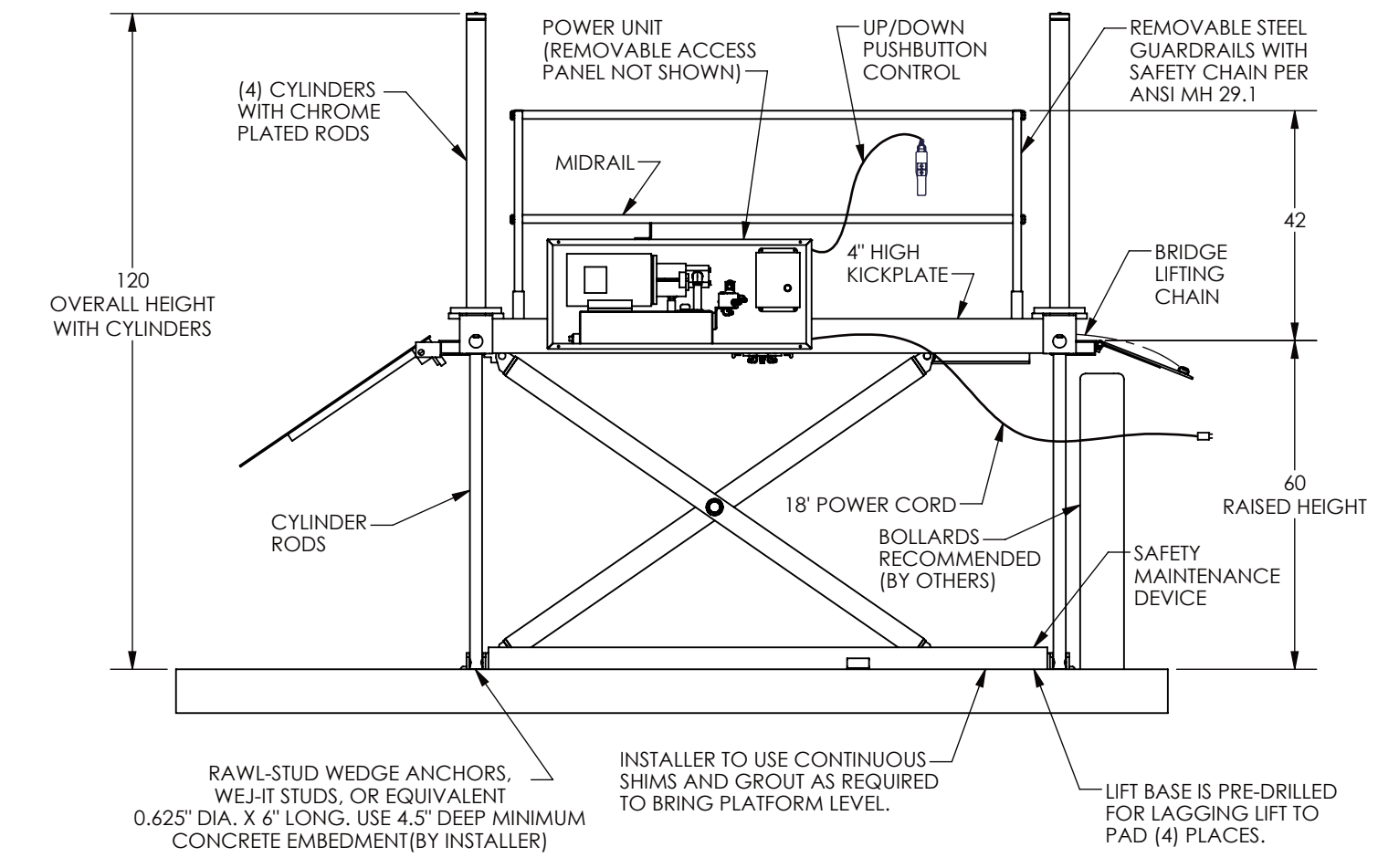
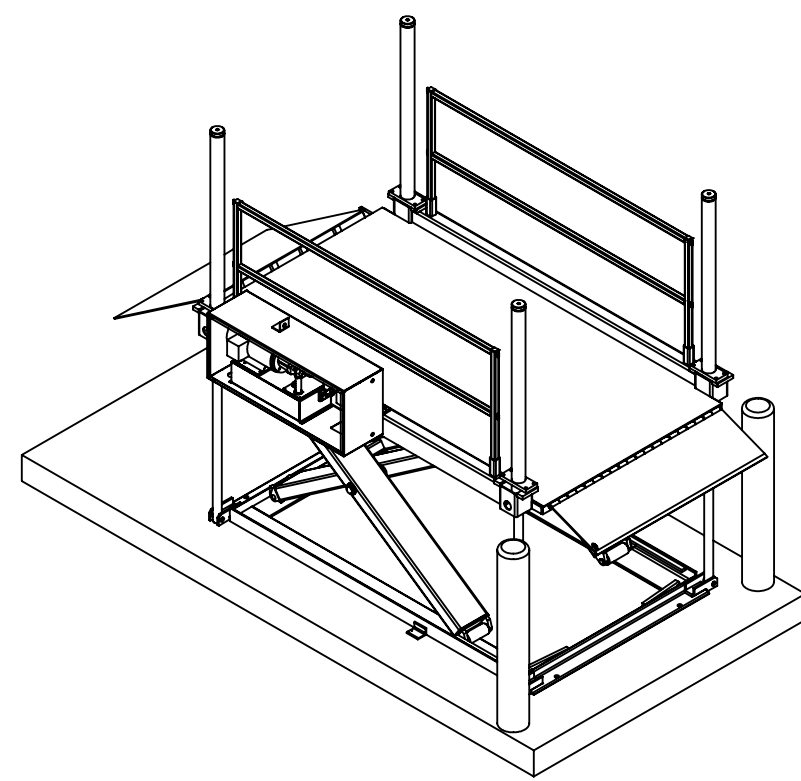

 ADVANCE LIFTS		Advance Lifts, Inc. 701 S. Kirk Road St. Charles, IL 60174		Phone : 630-584-9881 Fax : 630-584-6837	
SCALE	NTS	REVISIONS	BY	DATE	
DATE
DR'N	.				
CHKD	.				
JOB NAME					
DESC.	MODEL 610610			DWG.	B-
				REV.	

RAWL-STUD WEDGE ANCHORS, WEJ-IT STUDS, OR EQUIVALENT 0.625" DIA. X 6" LONG. USE 4.5" DEEP MINIMUM CONCRETE EMBEDMENT (BY INSTALLER)

INSTALLER TO USE CONTINUOUS SHIMS AND GROUT AS REQUIRED TO BRING PLATFORM LEVEL.

LIFT BASE IS PRE-DRILLED FOR LAGGING LIFT TO PAD (4) PLACES.